

RAPID SEAM PANEL PROFILE DETAIL
SCALE: 1:2 @A4

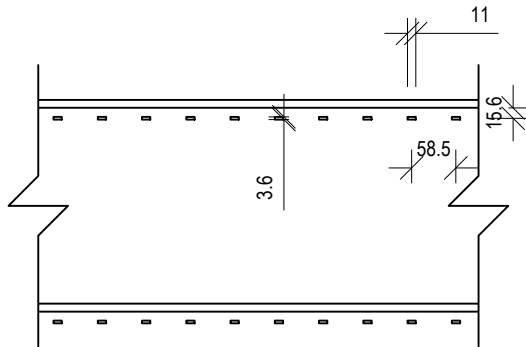

RAPID SEAM PANEL PART PLAN DETAIL
SCALE: 1:10 @A4

COVER WIDTH (mm):	265	465
BASE METAL THICKNESS (BMT) mm:	0.55	0.55
MINIMUM GUARANTEED YIELD STRENGTH (MPa):	300 (G300)	300 (G300)
COATING CLASS:	ACCEPTABLE CORROSION PROTECTION FOR METAL SHEET ROOFING, WALLING, FLASHINGS AND CAPPONGS (TABLE 7.2.2a, PAGES 147-148, ABCB HOUSING PROVISIONS STANDARD 2022)	
SHEET LENGTH (mm):	1. MINIMUM: 1000mm 2. MAXIMUM: 8000mm. NOTE: TO MINIMIZE THE EFFECTS OF OIL CANNING IN THE CLADDING, 8000mm MAXIMUM LENGTHS IS RECOMMENDED.	
MASS PER UNIT LENGTH (kg/m)		
METALLIC COATED:	Z275=0.29	Z275=0.29
PRE-PAINTED:	PCP=0.230	PCP=0.230
MASS PER UNIT AREA (kg/m ²)		
METALLIC COATED:	Z275=0.29	Z275=0.29
PRE-PAINTED:	PCP=0.230	PCP=0.230
APPLICABLE AUSTRALIAN STANDARDS:	1. AS 1397: CONTINUOUS HOT-DIP METALLIC COATED STEEL SHEET AND STRIP - COATINGS OF ZINC AND ZINC ALLOYED WITH ALUMINIUM AND MAGNESIUM. 2. AS/NZS 2728: PREFINISHED/PREPAINTED SHEET METAL PRODUCTS FOR INTERIOR/EXTERIOR BUILDING APPLICATIONS - PERFORMANCE REQUIREMENTS	

THIS DRAWING AND ALL CONSTRUCTION & INSTALLATION DETAILS SHALL BE STUDIED IN CONJUNCTION WITH THE STRUCTURAL ENGINEERING DESIGN CERTIFICATION AND SAFETY REPORT CONDITIONS STATED IN THAT DOCUMENT

SCALE	VARIABLES	JOB NAME: RAPID SEAM ROOF TYPICAL CONSTRUCTION DETAILS
DATE	15.02.23	
DESIGNED		DRAWING TITLE: RAPID SEAM PROFILE DETAILS & MATERIAL SPECIFICATIONS
DRAWN	W.B	
CHECKED	K.H	
APPROVED	A.C	



ZAMMIT METAL ROOFING
82 GLENDENNING ROAD, GLENDENNING
NSW 2170
www.zammitroofing.com.au

THE ENGINEERING DESIGN AND DETAILS ON THIS DRAWING REMAIN THE COPYRIGHT OF ZAMMIT METAL ROOFING AND SHALL NOT BE REPRODUCED IN ANY WAY WHATSOEVER, WITHOUT THE WRITTEN CONSENT OF ZAMMIT METAL ROOFING

No.	DATE	BY	CHECK	AMENDMENTS
B	24.10.24	W.B.K.H		UPDATED PROFILE
A	23.03.23	W.B.K.H		ISSUED FOR SPECIFICATIONS

No. IN SET	JOB No.	DRAWING No.	REV.
1 OF 1	ZAMM-1	DET-1	A

STANDARD - GENERAL LAP ENGAGEMENT PROCEDURE

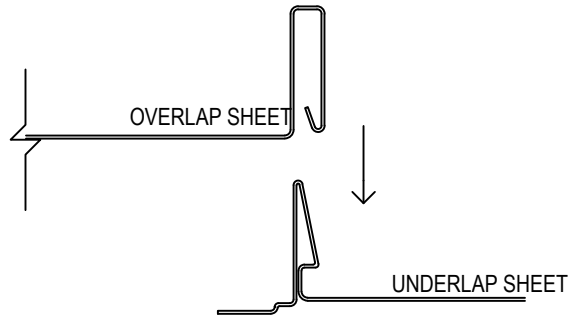

ALIGN THE OVERLAP SHEET ABOVE THE UNDERLAP SHEET AND APPLY PRESSURE BY HAND. ENGAGING THE OVERLAP AND UNDERLAP TOGETHER.

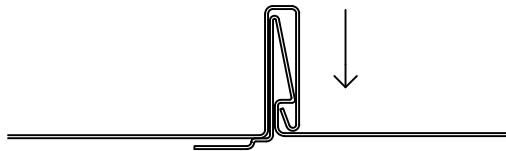

IF ROOF PITCH IS LESS THAN 7.5° INSTALL SILICONE BEAD ALONG THE BEND OF THE OVERLAP SHEET BEFORE ENGAGING THE OVERLAP SHEET AND INTERLOCKING ON THE UNDERLAP SHEET

THIS DRAWING AND ALL CONSTRUCTION & INSTALLATION DETAILS SHALL BE STUDIED IN CONJUNCTION WITH THE STRUCTURAL ENGINEERING DESIGN CERTIFICATION AND SAFETY REPORT CONDITIONS STATED IN THAT DOCUMENT

SCALE	VARIES	JOB NAME: RAPID SEAM ROOF TYPICAL CONSTRUCTION DETAILS
DATE	15.02.23	
DESIGNED		
DRAWN	W.B	
CHECKED	K.H	DRAWING TITLE: STANDARD PROCEDURE FOR LAP ENGAGEMENT
APPROVED	A.C	



ZAMMIT METAL ROOFING
82 GLENDENNING ROAD, GLENDENNING
NSW 2170
www.zammitroofing.com.au

B	24.10.24	W.B	K.H	UPDATED PROFILE
A	11.04.23	W.B	K.H	ISSUE FOR SPECIFICATION
No.	DATE	BY	CHECK	AMENDMENTS

No. IN SET	JOB No.	DRAWING No.	REV.
1 OF 1	ZAMM-1	DET-2	A

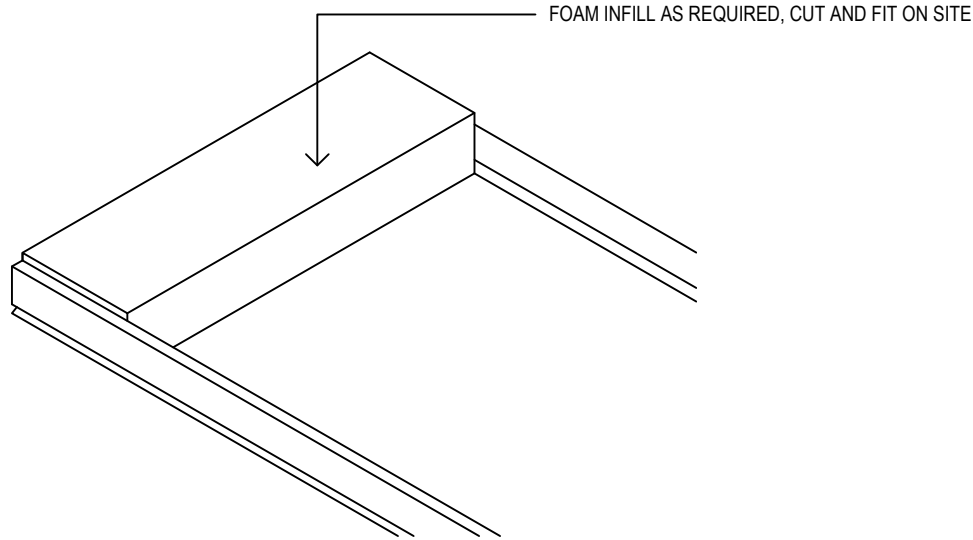

○ FOAM INFILL DETAIL
SCALE: 1:5 @A4

THIS DRAWING AND ALL CONSTRUCTION & INSTALLATION DETAILS SHALL BE STUDIED IN CONJUNCTION WITH THE STRUCTURAL ENGINEERING DESIGN CERTIFICATION AND SAFETY REPORT CONDITIONS STATED IN THAT DOCUMENT

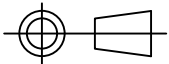
SCALE	VARIES	JOB NAME: RAPID SEAM ROOF TYPICAL CONSTRUCTION DETAILS
DATE	15.02.23	
DESIGNED		
DRAWN	W.B	
CHECKED	K.H	DRAWING TITLE: RAPID SEAM TYPICAL FOAM INFILL INSTALLATION DETAILS
APPROVED	A.C	
		



ZAMMIT METAL ROOFING
82 GLENDENNING ROAD, GLENDENNING
NSW 2170
www.zammitroofing.com.au

THE ENGINEERING DESIGN AND DETAILS ON THIS DRAWING REMAIN THE COPYRIGHT OF ZAMMIT METAL ROOFING AND SHALL NOT BE REPRODUCED IN ANY WAY WHATSOEVER, WITHOUT THE WRITTEN CONSENT OF ZAMMIT METAL ROOFING

No.	DATE	BY	CHECK	AMENDMENTS
B	24.10.24	W.B	K.H	UPDATED PROFILE
A	13.04.23	W.B	K.H	ISSUED FOR SPECIFICATIONS

No. IN SET	JOB No.	DRAWING No.	REV.
1 OF 1	ZAMM-1	DET-3	A

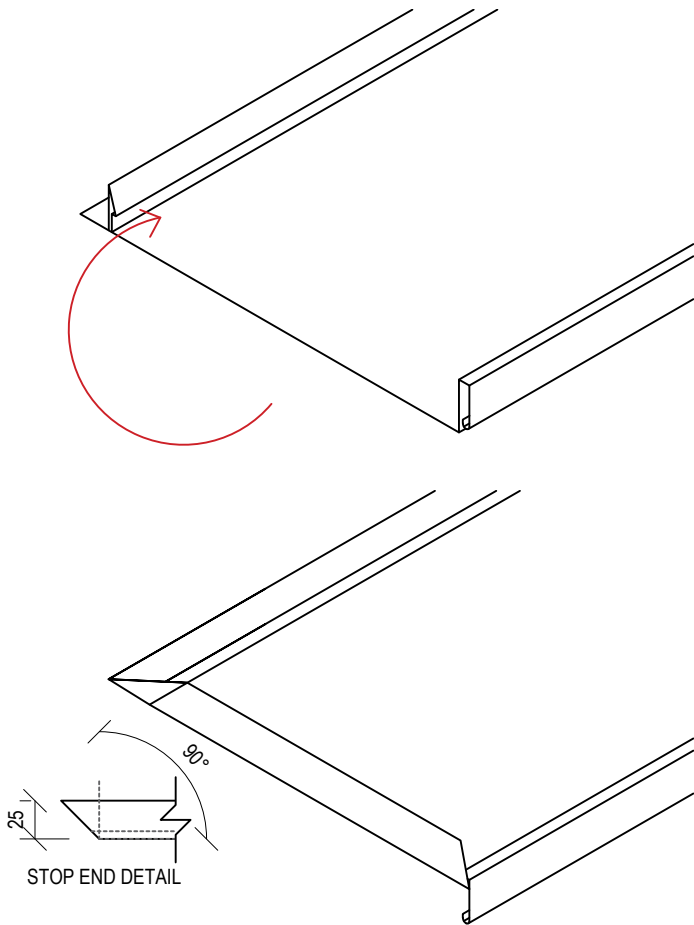

PANEL WITH STOP END/TURN UP

GENERAL STOP END DETAIL

PAN TURN UP PROCEDURE:

1. FOLD THE PANEL WITH STOP END/HEMMING TOOL BY PLACING THE EDGE OF THE TOOL IN BETWEEN EACH RIB
2. WITH PRESSURE LIFT THE TAB 90° TO CREATE STOP END ON THE PANEL

○ PAN TURN UP DETAIL
SCALE: 1:5 @A4

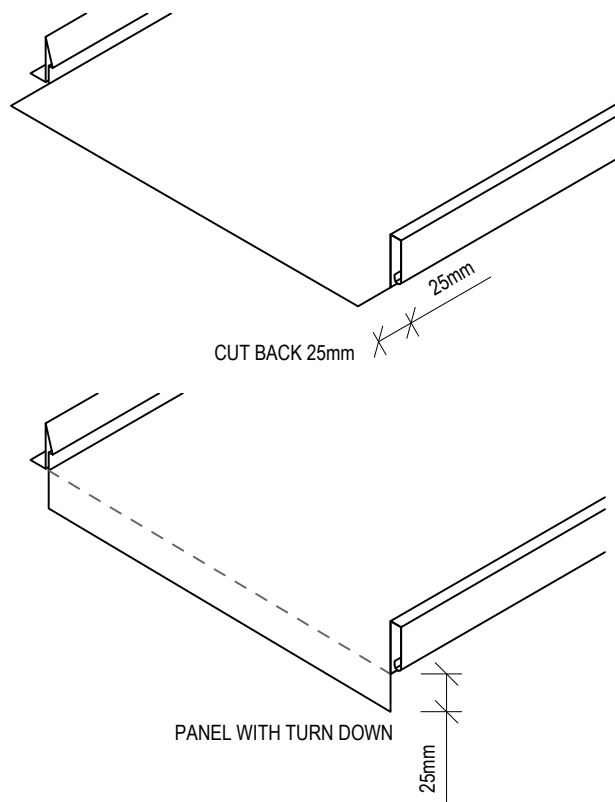

PANEL WITH TURN DOWN

GENERAL TURN DOWN DETAIL

PAN TURN DOWN PROCEDURE:

1. PANEL TO BE CUT 25mm LONGER IN LENGTH (LONGER THAN THE OVERALL FINISH LENGTH)
2. FOLD THE PANEL WITH STOP END/HEMMING TOOL BY PLACING THE EDGE OF THE TOOL ON THE EXTENDED 25mm LENGTH OF PANEL WITH PRESSURE AND ROTATION AT 90° TO CREATE THE TURN DOWN.

○ PAN TURN DOWN DETAIL
SCALE: 1:5 @A4

THIS DRAWING AND ALL CONSTRUCTION & INSTALLATION DETAILS SHALL BE STUDIED IN CONJUNCTION WITH THE STRUCTURAL ENGINEERING DESIGN CERTIFICATION AND SAFETY REPORT CONDITIONS STATED IN THAT DOCUMENT

SCALE	VARIABLES	JOB NAME:
DATE	15.02.23	RAPID SEAM ROOF TYPICAL CONSTRUCTION DETAILS
DESIGNED		
DRAWN	W.B	
CHECKED	K.H	DRAWING TITLE:
APPROVED	A.C	RAPID SEAM PAN TURN-UP & TURN-DOWN DETAILS

ZAMMIT
METAL ROOFING PRODUCTS PTY LTD

ZAMMIT METAL ROOFING
82 GLENDENNING ROAD, GLENDENNING
NSW 2170
www.zammitroofing.com.au

A	13.04.23	W.B/K.H	ISSUED FOR SPECIFICATIONS
No.	DATE	BY	CHECK AMENDMENTS

No. IN SET	JOB No.	DRAWING No.	REV.
1 OF 1	ZAMM-1	DET-4	A

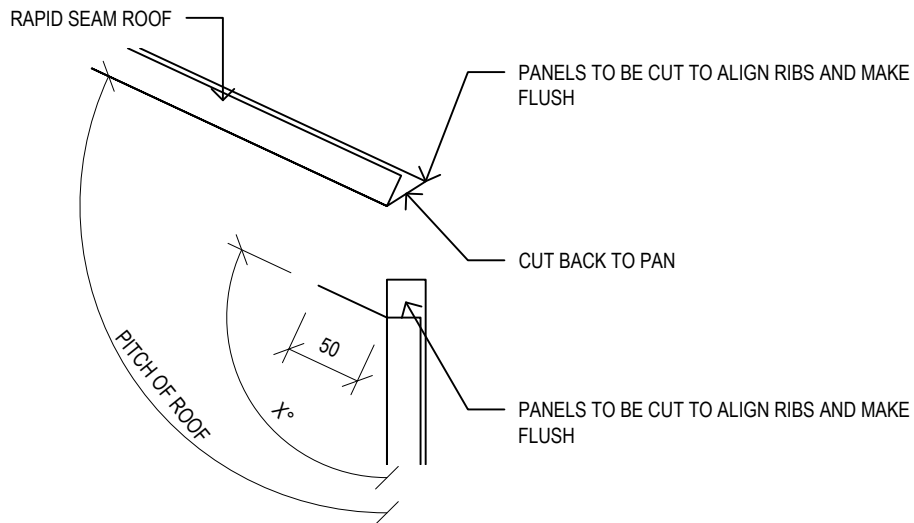
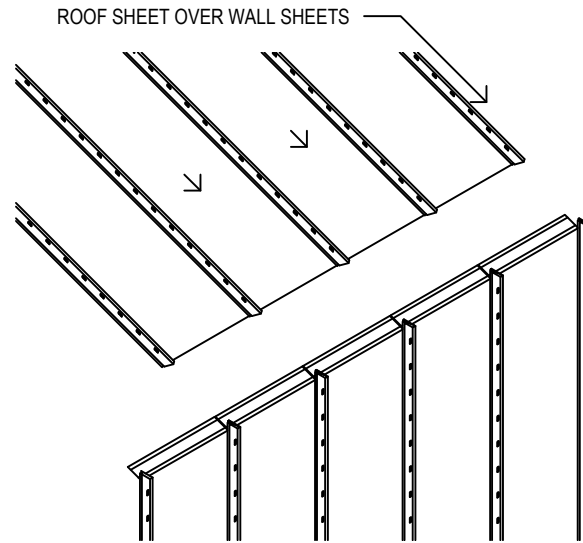
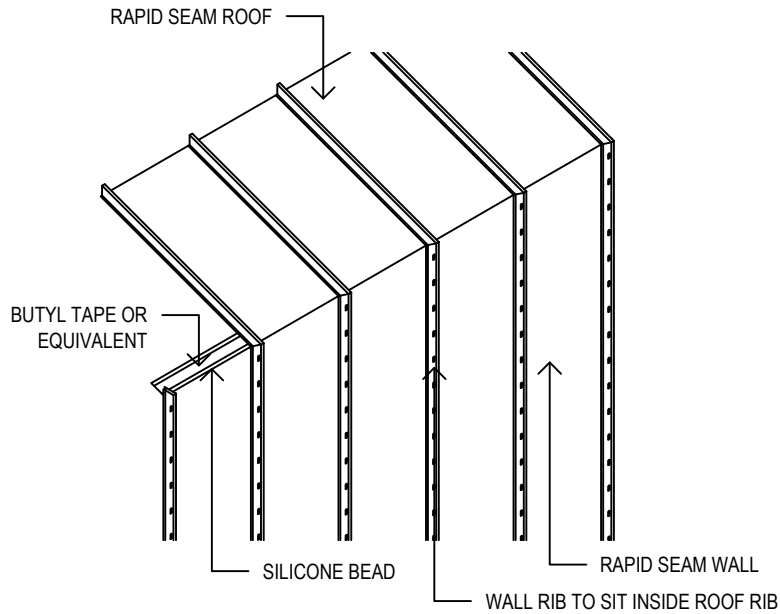

WALL TO ROOF DETAIL
SCALE: VARIES @A4

THIS DRAWING AND ALL CONSTRUCTION & INSTALLATION DETAILS SHALL BE STUDIED IN CONJUNCTION WITH THE STRUCTURAL ENGINEERING DESIGN CERTIFICATION AND SAFETY REPORT CONDITIONS STATED IN THAT DOCUMENT

SCALE	VARIES	JOB NAME: RAPID SEAM ROOF TYPICAL CONSTRUCTION DETAILS
DATE	15.02.23	
DESIGNED		
DRAWN	W.B	DRAWING TITLE: RAPID SEAM WALL TO ROOF DETAILS
CHECKED	K.H	
APPROVED	A.C	

		ZAMMIT METAL ROOFING	
<small>METAL ROOFING PRODUCTS PTY LTD</small>		82 GLENDENNING ROAD, GLENDENNING NSW 2170	
		www.zammitroofing.com.au	
No. IN SET	JOB No.	DRAWING No.	REV.
1 OF 1	ZAMM-1	DET-5	A

No.	DATE	BY	CHECK	AMENDMENTS
B	24.10.24	W.B	K.H	UPDATED PROFILE
A	13.04.23	W.B	K.H	ISSUED FOR SPECIFICATIONS

THE ENGINEERING DESIGN AND DETAILS ON THIS DRAWING REMAIN THE COPYRIGHT OF ZAMMIT METAL ROOFING AND SHALL NOT BE REPRODUCED IN ANY WAY WHATSOEVER, WITHOUT THE WRITTEN CONSENT OF ZAMMIT METAL ROOFING

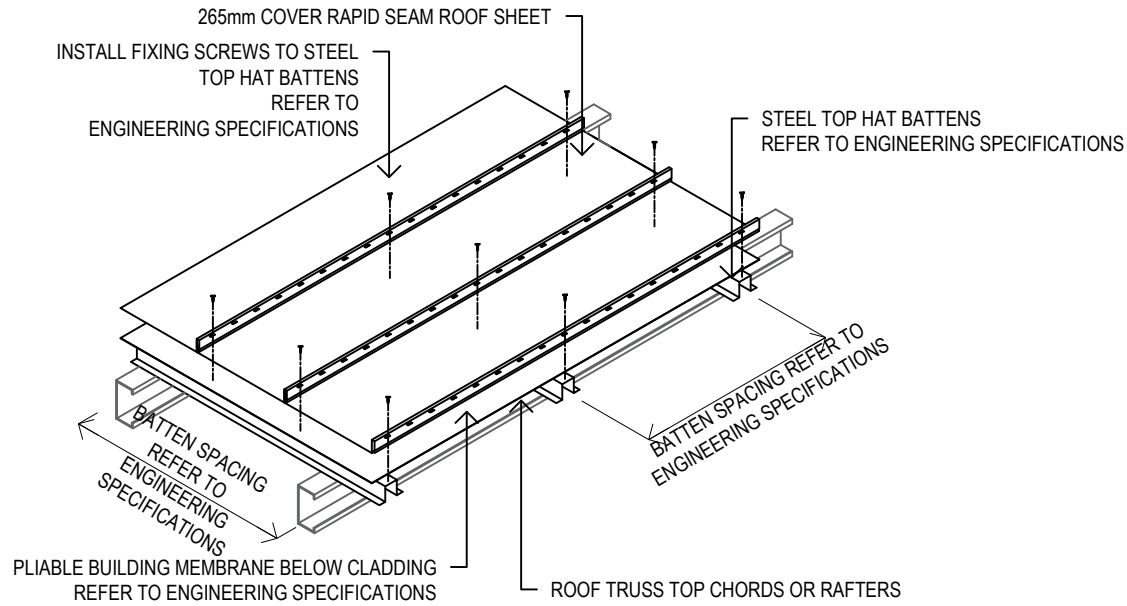

○ **RAPIDSEAM FIXING TO STEEL BATTENS DETAIL**
SCALE: 1:20 @A4

THIS DRAWING AND ALL CONSTRUCTION & INSTALLATION DETAILS SHALL BE STUDIED IN CONJUNCTION WITH THE STRUCTURAL ENGINEERING DESIGN CERTIFICATION AND SAFETY REPORT CONDITIONS STATED IN THAT DOCUMENT

SCALE	VARIABLES	JOB NAME: RAPID SEAM ROOF TYPICAL CONSTRUCTION DETAILS					
DATE	15.02.23						
DESIGNED							
DRAWN	W.B						
CHECKED	K.H	DRAWING TITLE: 265mm COVER RAPID SEAM TYPICAL FIXING TO STEEL BATTENS INSTALLATION DETAILS					
APPROVED	A.C						
		ZAMMIT METAL ROOFING 82 GLENDENNING ROAD, GLENDENNING NSW 2170 www.zammitroofing.com.au					
No. IN SET	1 OF 2	JOB No.	ZAMM-1	DRAWING No.	DET-6	REV.	A

B	24.10.24	W.B/K.H	UPDATED PROFILE
A	13.04.23	W.B/K.H	ISSUED FOR SPECIFICATIONS
No.	DATE	BY	CHECK AMENDMENTS

THE ENGINEERING DESIGN AND DETAILS ON THIS DRAWING REMAIN THE COPYRIGHT OF ZAMMIT METAL ROOFING AND SHALL NOT BE REPRODUCED IN ANY WAY WHATSOEVER, WITHOUT THE WRITTEN CONSENT OF ZAMMIT METAL ROOFING

**RAPID SEAM Roof 265mm Cover fixing to steel battens:
Engineering Specification for Non-Cyclonic Wind Regions**

1. **Minimum recommended roof slope:** 3°

2. **PLIABLE BUILDING MEMBRANE below Roof cladding:**

Material classifications as per AS 4200.1	Classification
Duty Classification	Medium (for unsupported metal sheet roofing spans less than or equal to 1200mm)
Vapour control Classification	Class 4 VCM category: Vapour permeable
Water control Classification	Water Barrier

NOTES:

- 1) Refer to Architectural/Architect's specifications and construction details for all other Classifications as per AS 4200.1 and compliance with NCC Performance Requirements.
- 2) Installation shall be in accordance with AS 4200.2

3. **Steel top hat battens:**

- 1) 40 mm overall depth x 32 mm overall top width - 75 mm overall bottom width; 0.55 mm BMT; steel grade G550.
- 2) Batten spacing: 600 mm maximum.
- 3) Batten span: As per Engineering Specifications.

4. **Fixing screws into steel top hat battens:**

- 1) 10 gauge (4.8 mm) - 16 threads per inch x 16 mm length wafer head metal screw.
- 2) Screw spacing: As per batten spacing.
- 3) Minimum 3-off threads shall be visible below the thickness of steel support member.
- 4) Corrosion Resistance Class 4. [AS 3566.2].

5. **Timber battens:**

- 1) MGP10 structural timber.
- 2) Batten size, spacing and span as per Engineering Specifications.

6. **Fixing screws into timber battens:**

- 1) 10 gauge (4.8 mm) - 12 threads per inch x length greater than 7 x screw shank diameter, wafer head Type 17 (T17) screw.
- 2) Screw spacing: As per batten spacing.
- 3) Depth of penetration into timber shall be greater than 7 x screw shank diameter as per AS1720.1.
- 4) Corrosion Resistance Class 4 [AS 3566.2].

7. **Insulation blankets below roof cladding, when specified:**

- 1) Refer to Architectural / Architect's specifications and construction details.
- 2) **Note:** Insulation blankets below roof cladding may require longer screw fasteners and greater care in installation.

8. **Mechanical Fastener penetration and length into supporting metal (steel, aluminium) and timber:**

- 1) Penetration into metal (steel, aluminium):
 - a) All connection specifications shall be determined by a Professional Engineer.
 - b) Screw penetration shall be in accordance with the screw manufacturer's recommendations.
 - c) At least 3-off threads shall be visible past or below the steel support - refer figure below.
 - d) The shank protection shall not reach the steel support - refer figure below.

- 2) Penetration into timber:
 - a) All connection specifications shall be determined by a Professional Engineer.
 - b) Depth of screw penetration shall be determined by a Professional Engineer in accordance with AS 1720.1 Timber structures - Design methods.
 - c) Depth of screw penetration shall be minimum 7 x shank diameter of screw.
- 3) Mechanical Fastener length:
 - a) The gauge and / or length of the screws may need to be increased when insulation blankets, boards, foam packers or any other boards/packers, are installed under the cladding.
 - b) Seeking advice from the screw manufacturer shall be considered, to determine the gauge, length and depth of screw penetration into metal and timber support.
- 4) Site trials and / or mock-up trials: To determine the suitability of the selected screws, site trials and / or mock-up trails shall be considered.

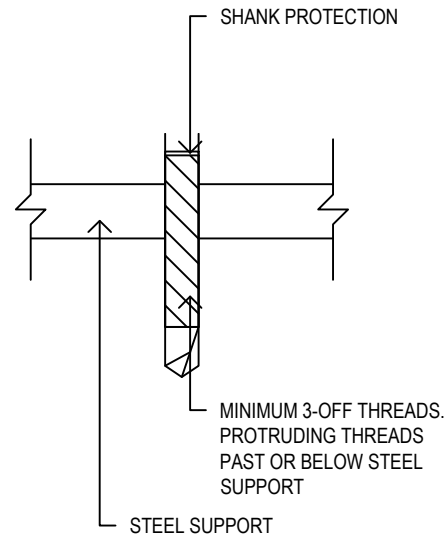

MECHANICAL FASTENER PENETRATION INTO METAL (STEEL/ALUMINIUM) DETAIL

SCALE: N.T.S. @A4

THIS DRAWING AND ALL CONSTRUCTION & INSTALLATION DETAILS SHALL BE STUDIED IN CONJUNCTION WITH THE STRUCTURAL ENGINEERING DESIGN CERTIFICATION AND SAFETY REPORT CONDITIONS STATED IN THAT DOCUMENT

SCALE	VARIES	JOB NAME: RAPID SEAM ROOF TYPICAL CONSTRUCTION DETAILS
DATE	15.02.23	
DESIGNED		
DRAWN	W.B	DRAWING TITLE: 265mm COVER RAPID SEAM TYPICAL FIXING TO STEEL BATTENS INSTALLATION DETAILS
CHECKED	K.H	
APPROVED	A.C	

ZAMMIT <small>METAL ROOFING PRODUCTS PTY LTD</small>		ZAMMIT METAL ROOFING 82 GLENDENNING ROAD, GLENDENNING NSW 2170 www.zammitroofing.com.au	
--	--	--	--

B	24.10.24	W.B/K.H	UPDATED PROFILE
A	13.04.23	W.B/K.H	ISSUED FOR SPECIFICATIONS
No.	DATE	BY	CHECK
			AMENDMENTS

No. IN SET	JOB No.	DRAWING No.	REV.
2 OF 2	ZAMM-1	DET-6	A

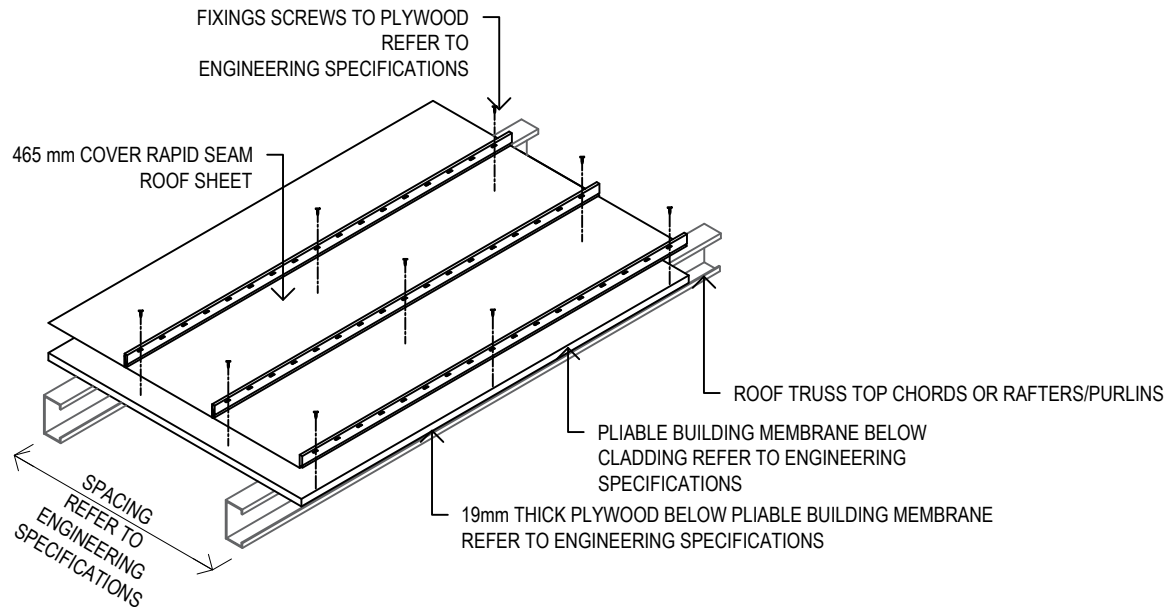

○ RAPIDSEAM FIXING TO PLYWOOD DETAIL
SCALE: 1:20 @A4

THIS DRAWING AND ALL CONSTRUCTION & INSTALLATION DETAILS SHALL BE STUDIED IN CONJUNCTION WITH THE STRUCTURAL ENGINEERING DESIGN CERTIFICATION AND SAFETY REPORT CONDITIONS STATED IN THAT DOCUMENT

SCALE	VARIABLES	JOB NAME: RAPID SEAM ROOF TYPICAL CONSTRUCTION DETAILS
DATE	15.02.23	
DESIGNED		
DRAWN	W.B	
CHECKED	K.H	DRAWING TITLE: 465mm COVER RAPID SEAM TYPICAL FIXING TO PLYWOOD INSTALLATION DETAILS
APPROVED	A.C	

	ZAMMIT METAL ROOFING		
	82 GLENDENNING ROAD, GLENDENNING NSW 2170 www.zammitroofing.com.au		

THE ENGINEERING DESIGN AND DETAILS ON THIS DRAWING REMAIN THE COPYRIGHT OF ZAMMIT METAL ROOFING AND SHALL NOT BE REPRODUCED IN ANY WAY WHATSOEVER, WITHOUT THE WRITTEN CONSENT OF ZAMMIT METAL ROOFING

No.	DATE	BY	CHECK	AMENDMENTS
B	24.10.24	W.B	K.H	UPDATED PROFILE
A	13.04.23	W.B	K.H	ISSUED FOR SPECIFICATIONS

No. IN SET	JOB No.	DRAWING No.	REV.
1 OF 2	ZAMM-1	DET-7	A

**RAPID SEAM Roof 465mm Cover fixing to plywood:
Engineering Specification for Non-Cyclonic Wind Regions**

1. **Minimum recommended roof slope:** 3°

2. **PLIABLE BUILDING MEMBRANE below Roof cladding:**

Material classifications as per AS 4200.1	Classification
Duty Classification	Medium (for unsupported metal sheet roofing spans less than or equal to 1200mm)
Vapour control Classification	Class 4 VCM category: Vapour permeable
Water control Classification	Water Barrier

NOTES:

- 1) Refer to Architectural/Architect's specifications and construction details for all other Classifications as per AS 4200.1 and compliance with NCC Performance Requirements.
- 2) Installation shall be in accordance with AS 4200.2

3. **FIXING SCREWS into structural plywood decking below pliable building membrane:**

- 1) Spacing @450 mm centres, through slots in sheet.
- 2) Screws: 10 gauge (4.8 mm) - 12 threads per inch x 25mm length, wafer head Type 17 (T17).
- 3) Corrosion Resistance Class 4 [AS 3566.2].

4. **Roof truss top chords or rafter supporting roof cladding, pliable building membrane and plywood:**

- 1) Size, spacing and span as per Engineering Specifications and detailing.

5. **Specification for design and installation details of Tongue & Grooved (T&G) Structural Plywood decking:**

- 1) Tongued and Grooved (T&G) Edges: Tongue & Grooved (T&G) structural plywood is tongued and grooved along the length of the panel to eliminate the need for nogging under panel edges. When panel ends are not tongued and grooved, they shall be supported with nogging.

2) Specification:

Length (mm) x Width (mm) x Thickness (mm) depending on batten spacing:	1) 2700 x 1200 x 19. 2) 2400 x 1200 x 19.
Plywood type and Standard	Structural plywood to AS/NZS 2269
Stress grade and ID code	F11 (19-30-7)
Face and back grades and glue bond type	CD - A BOND
EWPA/JAS-ANZ product certification stamp	EWPA/JAS-ANZ product certified
Formaldehyde emission class	E0 (to be confirmed by product designer/architect)
Treatment branded in accordance with AS/NZS 1604.3	AS/NZS 1604.3-H3 (outside above ground, subject to periodic moderate wetting and leaching)

- 3) All structural plywood supplied to site shall be checked for compliance prior to installation by the Builder and Installer. This shall be as per Engineered Wood Products Association of Australasia (EWPA) current recommendations - Structural plywood products certified by the EWPA are branded with the EWPA product certification stamp as well as the JAS-ANZ (Joint Accreditation Scheme of Australasia and New Zealand) mark. All structural engineering design certification shall be valid only when this check has been carried-out, photographically documented, signed-off and dated by a nominated Representative of the Builder and Installer.

- 4) Spans and Fixing of structural plywood decking into supporting roof truss top chords or rafters: As per Engineered Wood Products Association of Australasia and Engineering Specifications.

6. **Mechanical Fastener penetration and length into supporting metal (steel, aluminium) and timber:**

- 1) Penetration into metal (steel, aluminium):
 - a) All connection specifications shall be determined by a Professional Engineer.
 - b) Screw penetration shall be in accordance with the screw manufacturer's recommendations.
 - c) At least 3-off threads shall be visible past or below the steel support - refer figure below.
 - d) The shank protection shall not reach the steel support - refer figure below.
- 2) Penetration into timber:
 - a) All connection specifications shall be determined by a Professional Engineer.
 - b) Depth of screw penetration shall be determined by a Professional Engineer in accordance with AS 1720.1 Timber structures - Design methods.
 - c) Depth of screw penetration shall be minimum 7 x shank diameter of screw.
- 3) Mechanical Fastener length:
 - a) The gauge and / or length of the screws may need to be increased when insulation blankets, boards, foam packers or any other boards/packers, are installed under the cladding.
 - b) Seeking advice from the screw manufacturer shall be considered, to determine the gauge, length and depth of screw penetration into metal and timber support.
- 4) Site trials and / or mock-up trials: To determine the suitability of the selected screws, site trials and / or mock-up trails shall be considered.

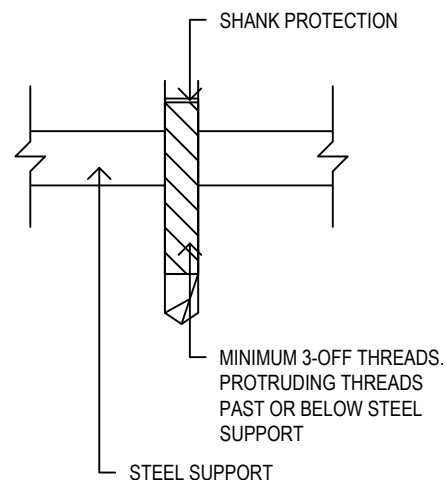

MECHANICAL FASTENER PENETRATION INTO METAL (STEEL/ALUMINIUM) DETAIL

SCALE: N.T.S. @A4

THIS DRAWING AND ALL CONSTRUCTION & INSTALLATION DETAILS SHALL BE STUDIED IN CONJUNCTION WITH THE STRUCTURAL ENGINEERING DESIGN CERTIFICATION AND SAFETY REPORT CONDITIONS STATED IN THAT DOCUMENT

SCALE	VARIES	JOB NAME: RAPID SEAM ROOF TYPICAL CONSTRUCTION DETAILS
DATE	15.02.23	
DESIGNED		
DRAWN	W.B	DRAWING TITLE: 465mm COVER RAPID SEAM TYPICAL FIXING TO PLYWOOD INSTALLATION DETAILS
CHECKED	K.H	
APPROVED	A.C	

ZAMMIT METAL ROOFING PRODUCTS PTY LTD	ZAMMIT METAL ROOFING 82 GLENDENNING ROAD, GLENDENNING NSW 2170 www.zammitroofing.com.au
---	--

No. IN SET	JOB No.	DRAWING No.	REV.
2 OF 2	ZAMM-1	DET-7	A

B	24.10.24	W.B/K.H	UPDATED PROFILE
A	13.04.23	W.B/K.H	ISSUED FOR SPECIFICATIONS
No.	DATE	BY	CHECK AMENDMENTS

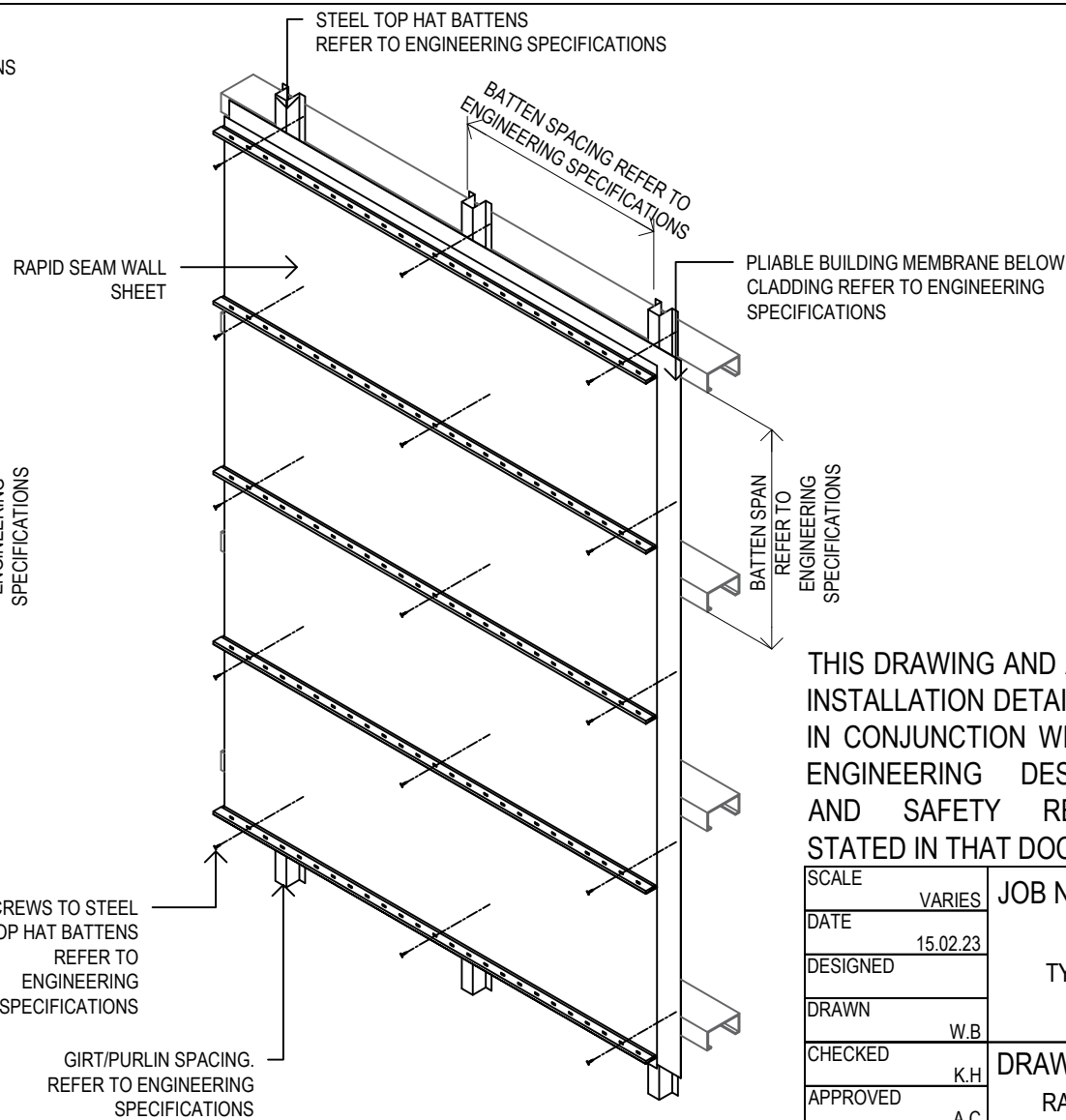
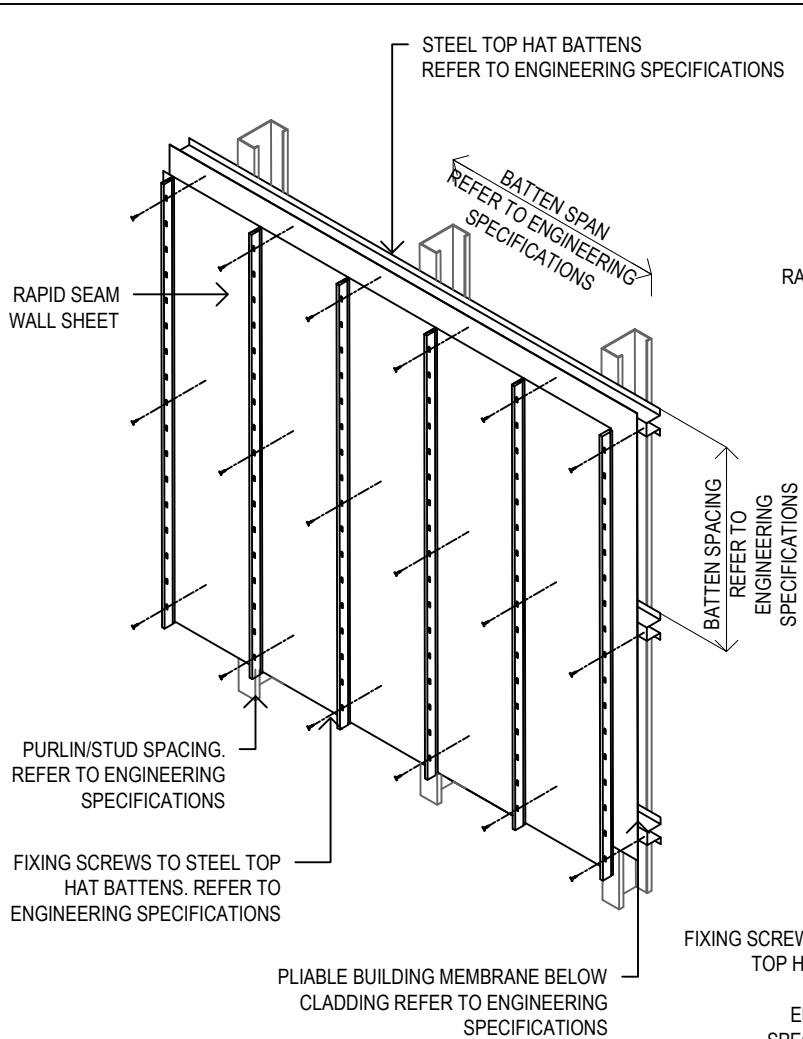

THIS DRAWING AND ALL CONSTRUCTION & INSTALLATION DETAILS SHALL BE STUDIED IN CONJUNCTION WITH THE STRUCTURAL ENGINEERING DESIGN CERTIFICATION AND SAFETY REPORT CONDITIONS STATED IN THAT DOCUMENT

SCALE	VARIABLES	JOB NAME: RAPID SEAM WALL TYPICAL CONSTRUCTION DETAILS
DATE	15.02.23	
DESIGNED		
DRAWN	W.B	DRAWING TITLE: RAPID SEAM WALL FIXING TO STEEL BATTEN TYPICAL INSTALLATION DETAILS
CHECKED	K.H	
APPROVED	A.C	

ZAMMIT
METAL ROOFING PRODUCTS PTY LTD

ZAMMIT METAL ROOFING
82 GLENDENNING ROAD, GLENDENNING
NSW 2170
www.zammitroofing.com.au

No. IN SET	JOB No.	DRAWING No.	REV.
1 OF 2	ZAMM-1	DET-8	A

VERTICAL RAPIDSEAM WALL
FIXING TO STEEL BATTEN DETAIL
SCALE: 1:20 @A4

HORIZONTAL RAPIDSEAM WALL
FIXING TO STEEL BATTEN DETAIL
SCALE: 1:20 @A4

THE ENGINEERING DESIGN AND DETAILS ON THIS DRAWING REMAIN THE COPYRIGHT OF ZAMMIT METAL ROOFING AND SHALL NOT BE REPRODUCED IN ANY WAY WHATSOEVER, WITHOUT THE WRITTEN CONSENT OF ZAMMIT METAL ROOFING

No.	DATE	BY	CHECK	AMENDMENTS
B	24.10.24	W.B	K.H	UPDATED PROFILE
A	13.04.23	W.B	K.H	ISSUED FOR SPECIFICATIONS

**RAPID SEAM WALL 265mm and 465mm Cover fixing to steel battens:
Engineering Specification for Non-Cyclonic Wind Regions**

1. PLIABLE BUILDING MEMBRANE below cladding:

Material classifications as per AS 4200.1	Classification
Duty Classification	Light Wall
Vapour control Classification	Class 4 VCM category: Vapour permeable
Water control Classification	Water Barrier

NOTES:

- 1) Refer to Architectural/Architect's specifications and construction details for all other Classifications as per AS 4200.1 and compliance with NCC Performance Requirements.
- 2) Installation shall be in accordance with AS 4200.2

2. Steel top hat battens:

- 1) 40 mm overall depth x 32 mm overall top width - 75 mm overall bottom width; 0.55 mm BMT; steel grade G550.
- 1) Batten spacing:
 - a) 600 mm maximum for 265 mm cover
 - a) 450 mm maximum for 465 mm cover
- 2) Batten span: As per Engineering Specifications.

3. FIXING SCREWS into steel top hat battens:

- 1) 10 gauge (4.8 mm) - 16 threads per inch x 16 mm length wafer head metal screw.
- 2) Screw spacing: As per batten spacing.
- 3) Minimum 3-off threads shall be visible below the thickness of steel support member.
- 4) Corrosion Resistance Class 4. [AS 3566.2].

4. Timber battens:

- 1) MGP10 structural timber.
- 2) Batten size, spacing and span as per Engineering Specifications.

5. FIXING SCREWS into timber battens:

- 1) 10 gauge (4.8 mm) - 12 threads per inch x length greater than 7 x screw shank diameter, wafer head Type 17 (T17) screw.
- 2) Screw spacing: As per batten spacing.
- 3) Depth of penetration into timber shall be greater than 7 x screw shank diameter as per AS1720.1.
- 4) Corrosion Resistance Class 4 [AS 3566.2].

6. Insulation blankets below wall cladding, when specified:

- 1) Refer to Architectural / Architect's specifications and construction details.
- 2) **Note:** Insulation blankets below roof cladding may require longer screw fasteners and greater care in installation.

7. Mechanical Fastener penetration and length into supporting metal (steel, aluminium) and timber:

- 1) Penetration into metal (steel, aluminium):
 - a) All connection specifications shall be determined by a Professional Engineer.
 - b) Screw penetration shall be in accordance with the screw manufacturer's recommendations.
 - c) At least 3-off threads shall be visible past or below the steel support - refer figure below.
 - d) The shank protection shall not reach the steel support - refer figure below.
- 2) Penetration into timber:
 - a) All connection specifications shall be determined by a Professional Engineer.
 - b) Depth of screw penetration shall be determined by a Professional Engineer in accordance with AS 1720.1 Timber structures - Design methods.
 - c) Depth of screw penetration shall be minimum 7 x shank diameter of screw.
- 3) Mechanical Fastener length:
 - a) The gauge and / or length of the screws may need to be increased when insulation blankets, boards, foam packers or any other boards/packers, are installed under the cladding.
 - b) Seeking advice from the screw manufacturer shall be considered, to determine the gauge, length and depth of screw penetration into metal and timber support.
- 4) Site trials and / or mock-up trials: To determine the suitability of the selected screws, site trials and / or mock-up trails shall be considered.

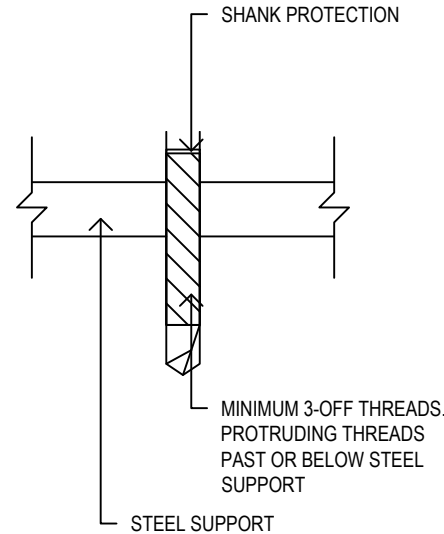

MECHANICAL FASTENER PENETRATION INTO METAL (STEEL/ALUMINIUM) DETAIL

SCALE: N.T.S. @A4

THIS DRAWING AND ALL CONSTRUCTION & INSTALLATION DETAILS SHALL BE STUDIED IN CONJUNCTION WITH THE STRUCTURAL ENGINEERING DESIGN CERTIFICATION AND SAFETY REPORT CONDITIONS STATED IN THAT DOCUMENT

SCALE	VARIES	JOB NAME: RAPID SEAM WALL TYPICAL CONSTRUCTION DETAILS
DATE	15.02.23	
DESIGNED		
DRAWN	W.B	DRAWING TITLE: RAPID SEAM WALL FIXING TO STEEL BATTEN TYPICAL INSTALLATION DETAILS
CHECKED	K.H	
APPROVED	A.C	

ZAMMIT
METAL ROOFING PRODUCTS PTY LTD

ZAMMIT METAL ROOFING
82 GLENDENNING ROAD, GLENDENNING
NSW 2170
www.zammitroofing.com.au

No.	DATE	BY	CHECK	AMENDMENTS
B	24.10.24	W.B	K.H	UPDATED PROFILE
A	13.04.23	W.B	K.H	ISSUED FOR SPECIFICATIONS

No. IN SET	JOB No.	DRAWING No.	REV.
2 OF 2	ZAMM-1	DET-8	A

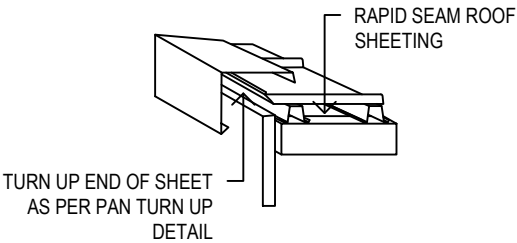
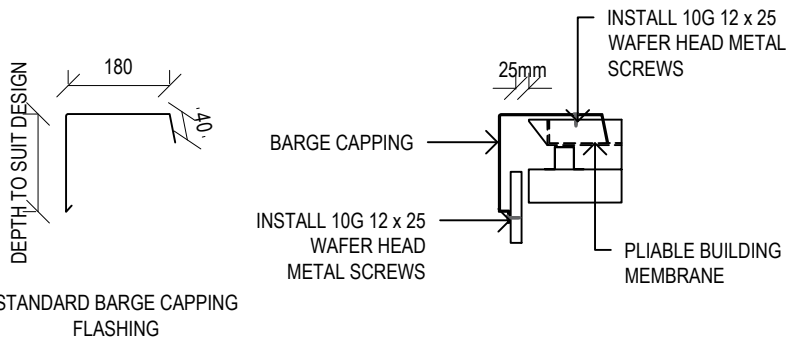

TYPICAL DETAIL AT BARGE CAPPING - METAL BATTEN*

SCALE: N.T.S

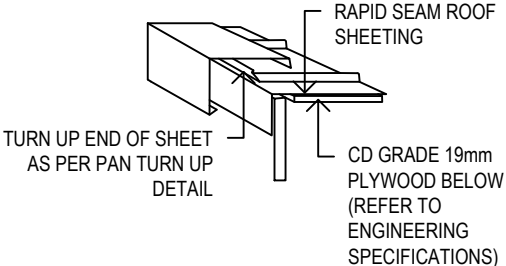
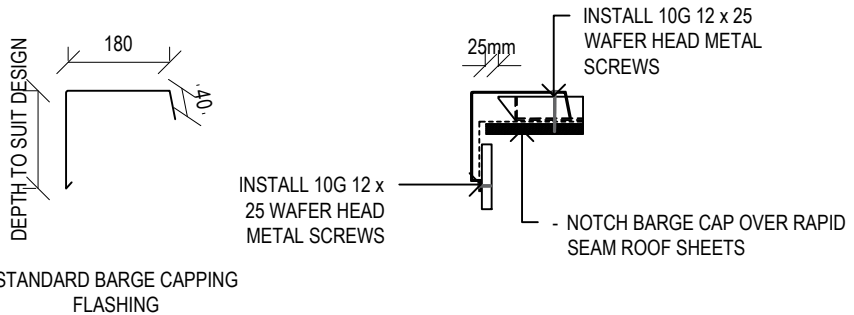

TYPICAL DETAIL AT BARGE CAPPING - PLYWOOD*

SCALE: N.T.S

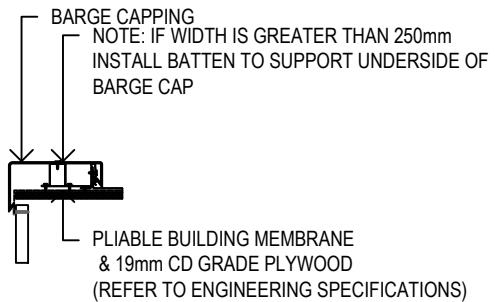
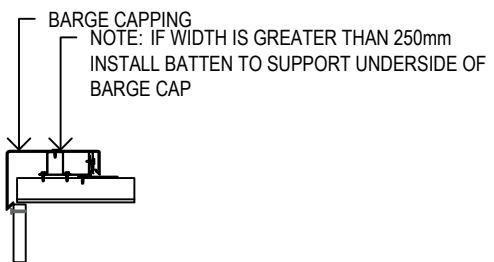

TYPICAL BARGE DETAIL - METAL BATTEN*

SCALE: N.T.S

TYPICAL BARGE DETAIL - PLYWOOD*

SCALE: N.T.S

- *FOR ALL FLASHINGS AND CAPPINGS, THE FOLLOWING SHALL BE IN ACCORDANCE WITH THE REQUIREMENTS SPECIFIED IN: -
1. AS 1562.1: DESIGN AND INSTALLATION OF SHEET ROOF AND WALL CLADDING. PART 1: METAL.
 2. SA HB 39: INSTALLATION CODE FOR METAL ROOF AND WALL CLADDING.
- 1) MATERIALS.
 - 2) MATERIAL COMPATIBILITY.
 - 3) PROVISION FOR EXPANSION & CONTRACTION.
 - 4) SIZES & COVERS.
 - 5) MECHANICAL FASTENING - FASTENER TYPES, FASTENER FREQUENCY.
 - 6) SPECIAL FOLDS AND ANTI-CAPILLARY BREAKS.
 - 7) WALL AND STEP FLASHINGS.
 - 8) LEAD FLASHINGS.
 - 9) PENETRATIONS - COLLAR FLASHINGS, LARGE PENETRATIONS
 - 10) ALL OTHER FLASHINGS AND CAPPINGS.

THIS DRAWING AND ALL CONSTRUCTION & INSTALLATION DETAILS SHALL BE STUDIED IN CONJUNCTION WITH THE STRUCTURAL ENGINEERING DESIGN CERTIFICATION AND SAFETY REPORT CONDITIONS STATED IN THAT DOCUMENT

SCALE	VARIABLES	JOB NAME: RAPID SEAM ROOF TYPICAL CONSTRUCTION DETAILS
DATE	05.06.23	
DESIGNED		
DRAWN	W.B	DRAWING TITLE: RAPID SEAM ROOF TYPICAL INSTALLATION DETAILS - FLASHINGS & CAPPINGS
CHECKED	K.H	
APPROVED	A.C	

ZAMMIT METAL ROOFING
82 GLEN DENNING ROAD, GLEN DENNING NSW 2170
www.zammitroofing.com.au

No.	DATE	BY	CHECK	AMENDMENTS
B	24.10.24	W.B	K.H	UPDATED PROFILE
A	19.06.23	W.B	K.H	ISSUE FOR SPECIFICATIONS

No. IN SET	JOB No.	DRAWING No.	REV.
1 OF 2	ZAMM-1	DET-9	A

THE ENGINEERING DESIGN AND DETAILS ON THIS DRAWING REMAIN THE COPYRIGHT OF ZAMMIT METAL ROOFING AND SHALL NOT BE REPRODUCED IN ANY WAY WHATSOEVER, WITHOUT THE WRITTEN CONSENT OF ZAMMIT METAL ROOFING

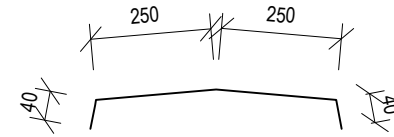
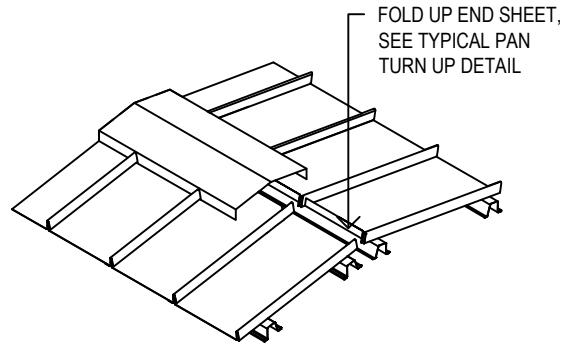
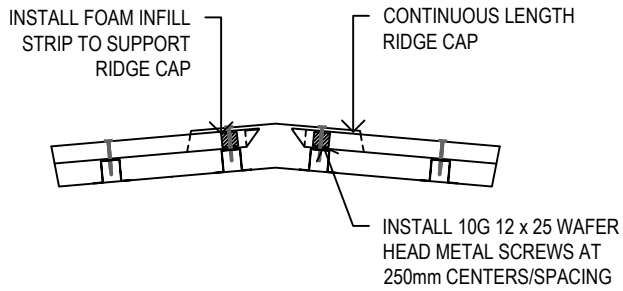

TYP. RIDGE CAPPING DIMENSION

RIDGE CAP DETAIL - METAL BATTEN
SCALE: N.T.S

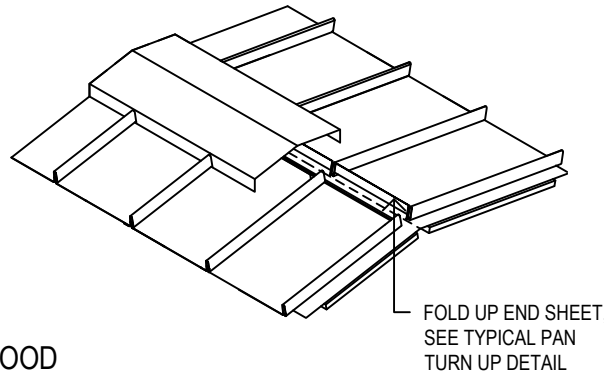
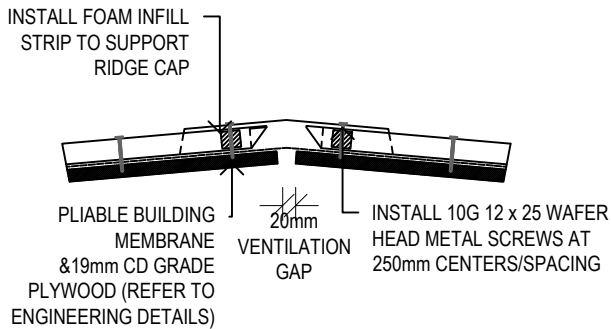

RIDGE DETAIL - METAL BATTEN & PLYWOOD
SCALE: N.T.S

THIS DRAWING AND ALL CONSTRUCTION & INSTALLATION DETAILS SHALL BE STUDIED IN CONJUNCTION WITH THE STRUCTURAL ENGINEERING DESIGN CERTIFICATION AND SAFETY REPORT CONDITIONS STATED IN THAT DOCUMENT

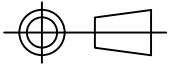
SCALE	VARIES	JOB NAME: RAPID SEAM ROOF TYPICAL CONSTRUCTION DETAILS
DATE	05.06.23	
DESIGNED		
DRAWN	W.B	DRAWING TITLE: RAPID SEAM ROOF TYPICAL INSTALLATION DETAILS - FLASHINGS & CAPPINGS
CHECKED	K.H	
APPROVED	A.C	
		



ZAMMIT METAL ROOFING
82 GLENDENNING ROAD, GLENDENNING
NSW 2170
www.zammitroofing.com.au

THE ENGINEERING DESIGN AND DETAILS ON THIS DRAWING REMAIN THE COPYRIGHT OF ZAMMIT METAL ROOFING AND SHALL NOT BE REPRODUCED IN ANY WAY WHATSOEVER, WITHOUT THE WRITTEN CONSENT OF ZAMMIT METAL ROOFING

No.	DATE	BY	CHECK	AMENDMENTS
B	24.10.24	W.B	K.H	UPDATED PROFILE
A	19.06.23	W.B	K.H	ISSUE FOR SPECIFICATIONS

No. IN SET	JOB No.	DRAWING No.	REV.
2 OF 2	ZAMM-1	DET-9	A